

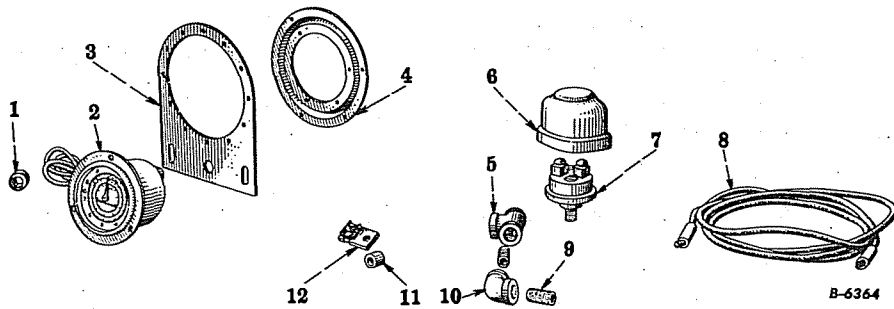

ATTACHMENTS



Reference numbers only are shown in illustration. Use I H part numbers in ordering.
Unnumbered parts in the illustrations are the same as corresponding parts shown with numbers.

ENGINE HOUR METER (Special)

	356 735 R91	ATTACHMENT, ENGINE HOUR METER (FOR TRACTORS EQUIPPED WITH ELECTRIC STARTING AND/OR LIGHTING)	1
1	187 540	GROMMET, RUBBER (OPTIONAL WITH 33 560 D)	1
1	33 560 D	GROMMET, RUBBER (OPTIONAL WITH 187 540)	1
2	356 736 R91	METER, HOUR	1
	132 705	SCREW, SLOTTED-RD-HD., CD-PLTD., No. 6-32NC x 1/2"	3
	138 526	WASHER, LOCK, INTERNAL-TOOTH, CD-PLTD., No. 6	3
3	356 738 R1	BRACKET, MOUNTING, HOUR METER	1
	171 589	SCREW, SELF-TAPPING, SLOTTED-RD-HD., CD-PLTD., No. 6-32 x 1/2"	2
	125 751	WASHER, LOCK, EXTERNAL-TOOTH, CD-PLTD., No. 12	2
	446 179	WASHER, PLAIN, CD-PLTD., 1/2" O.D. x 1/4" I.D. x No. 18 GA	2
4	356 737 R91	DAMPER, HOUR METER VIBRATION	1
	132 705	SCREW, SLOTTED-RD-HD., CD-PLTD., No. 6-32NC x 1/2"	3
	138 526	WASHER, LOCK, INTERNAL-TOOTH, CD-PLTD., No. 6	3
5	105 416	TEE, PIPE, 1/8"	1
6	354 558 R1	SHIELD, PRESSURE SWITCH	1
7	356 739 R91	SWITCH, PRESSURE, HOUR METER	1
8	70 261 D	CABLE, PRESSURE SWITCH TO JUNCTION BLOCK	1
9	144 580	NIPPLE, CLOSE, 1/8 x 7/8"	2
10	105 412	ELBOW, M.I., 90° x 1/8"	1
11	354 260 R1	SPACER, JUNCTION BLOCK	1
12	42 915 D	BLOCK, JUNCTION	1
	120 614	NUT, HEX., CD-PLTD., No. 10-32NF	1
	132 919	SCREW, SLOTTED-RD-HD., CD-PLTD., No. 10-32NF x 7/8"	1
	120 217	WASHER, LOCK, MEDIUM, CD-PLTD., No. 10	1